

MAS-BT 403

Dr aèi alata
Werkzeugaufnahmen
Toolholders
Porte-outils

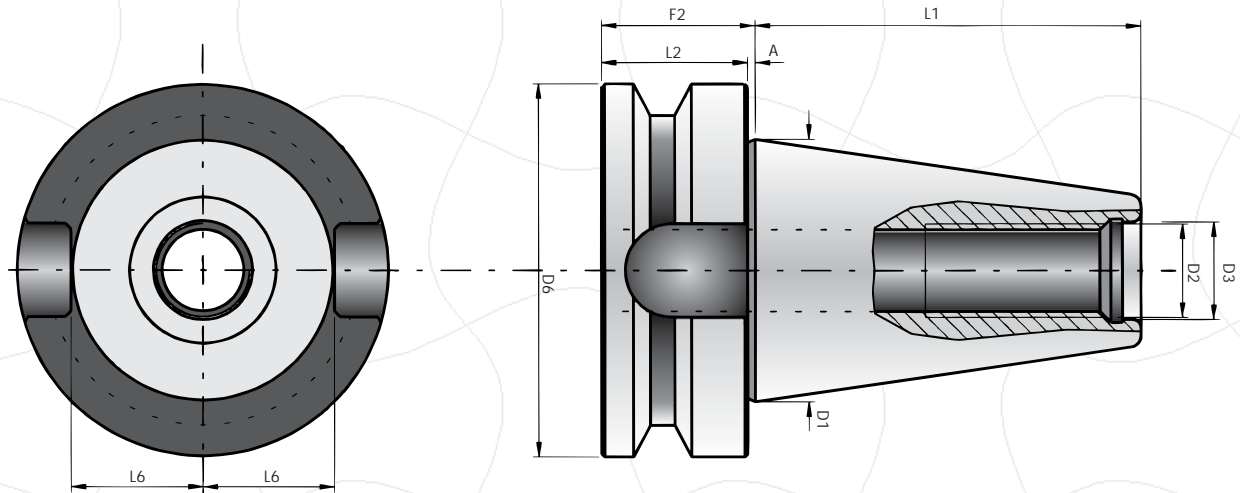

Werkzeugaufnahmen MAS-BT -technische information-
Toolholders MAS-BT -technical information-
Outils de serrage MAS-BT -Information techniques-



Konus

Kegel
Taper
Cone

	D1	D2	D3	D6	L1	L2	L6	A	F2
40	44,45	M16	17	63	65,40	25,00	22,50	2,00	min.35
50	69,85	M24	25	100	101,80	35,00	35,30	3,00	min.35

Balans : Standardno G6.3-12000^{min-1}. Fino balansiranje na upit

Wuchtgüte : G6.3-12000^{min-1}. Feinwuchten auf anfrage.

Balancing grade : G6.3-12000^{min-1}. Fine balancing on request.

Equilibrage : G6.3-12000^{min-1}. Beau Equilibrage sur demande.

Materijal : Legirani èelik, èvrstoæe u jezgri najmanje 980 N/mm².

Material : Legierter Einsatzstahl mit min. 980N/mm² Zugfestigkeit im Kern.

Material : Case hardened steel with min. 980N/mm² tensile strength in core.

Materiau : Chasis d' allie en acier de cementation. Resistance mecanique de 980N/mm².

Izvedba : Cementirano 0,8-0,2 mm. Kaljeno na 58 ± 2 HRC. Brunirano

Ausführung : Einsatzgehärtet 58 ± 2 HRC. Hartetiefe 0,8-0,2 mm. Brüniert.

Execution : Case hardened 58 ± 2 HRC. Depth of case 0,8-0,2 mm. Black oxided.

Execution : Cemente HRC 58 ± 2. Eppaisseur de cementation 0,8-0,2 mm. Bruni.

Toènost : Kut konusa klasa AT3, prema DIN2080. Hrapavost Ra < 0.2

Genauigkeit : Kegewinkel - Toleranzqualität AT3. Oberflächenrauigkeit Ra<0.2

Accuracy : Taper angle AT3 quality class. Roughness Ra<0.2

Precision : Angle des cone AT3 catégorie de qualité. Rugosite Ra<0.2

Zwischenhülsen für Zylinderschäfte - FORMGRIP

Adaptor sleeves for parallel shanks - FORMGRIP

Douilles intermediaires pour queues cylindriques - FORMGRIP

Isporuka : sa ugrađenim vijcima za stezanje

Lieferumfang : mit eingebauter Spannschraube

Delivery : adaptor with built in locking screw

Livraison : compris vis de serrage

MAS-BT
40 G2.5-15.000

d1	x1	d2	d3	MAS-BT 403 AD+B	EUR
6	100	17	23	WE06.B44.100F	60.00
6	130	17	28	WE06.B44.130F	70.00
6	160	17	29	WE06.B44.160F	90.00
8	100	21	27	WE08.B44.100F	60.00
8	130	21	32	WE08.B44.130F	70.00
8	160	21	33	WE08.B44.160F	90.00
10	100	24	30	WE10.B44.100F	60.00
10	130	24	35	WE10.B44.130F	70.00
10	160	24	36	WE10.B44.160F	90.00
12	100	27	33	WE12.B44.100F	60.00
12	130	27	38	WE12.B44.130F	70.00
12	160	27	39	WE12.B44.160F	90.00
14	100	29	35	WE14.B44.100F	60.00
14	130	29	40	WE14.B44.130F	70.00
14	160	29	41	WE14.B44.160F	90.00
16	100	33	39	WE16.B44.100F	60.00
16	130	33	44	WE16.B44.130F	70.00
16	160	33	45	WE16.B44.160F	90.00
18	100	35	41	WE18.B44.100F	60.00
18	130	35	46	WE18.B44.130F	70.00
18	160	35	47	WE18.B44.160F	90.00
20	100	39	45	WE20.B44.100F	60.00
20	130	39	48	WE20.B44.130F	70.00
20	160	39	49	WE20.B44.160F	90.00
25	100	47	47	WE25.B44.100F	60.00
25	130	47	47	WE25.B44.130F	70.00
25	160	47	47	WE25.B44.160F	90.00
32	100	57	57	WE32.B44.100F	60.00
32	130	57	57	WE32.B44.130F	70.00
32	160	57	57	WE32.B44.160F	90.00

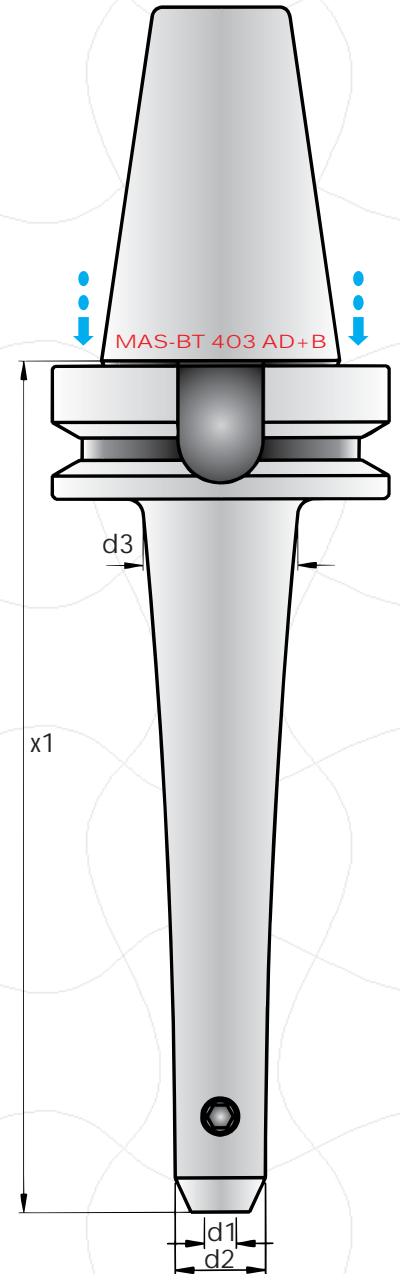

Niklovano
Nickel beschitet
Nickel coated
Couche de Nickel

Rezervni dijelovi/Ersatzteile/Spare parts/Accessoires

Weldon	M	code	EUR
6	M6 x 6	WE.06.F	2.00
8	M8 x 7.5	WE.08.F	2.00
10	M10 x 8	WE.10.F	2.00
12	M12 x 8	WE.12.F	2.00
14	M12 x 8.5	WE.14.F	2.00



Weldon	M	code	EUR
16	M14 x 8.5	WE.16.F	3.00
18	M14 x 8.5	WE.18.F	3.00
20	M16 x 10	WE.20.F	3.00
25	M18 x 2 x 11,5	WE.25.F	4.00
32	M20 x 2 x 13	WE.32.F	4.00

Zwischenhùslen für Zylinderschäfte
Adaptor sleeves for parallel shanks
Douilles intermediaires pour queues cylindriques

Isporuka : sa ugrađenim vijcima za stezanje

Lieferumfang : mit eingebauter Spannschraube

Delivery : adaptor with built in locking screw

Livraison : compris vis de serrage

MAS-BT
40

d1	x1	d2	MAS-BT403	EUR
6	50	25	WE06.B40.050	30.00
6	100	25	WE06.B40.100	35.00
6	160	25	WE06.B40.160	50.00
8	50	28	WE08.B40.050	30.00
8	100	28	WE08.B40.100	35.00
8	160	28	WE08.B40.160	50.00
10	63	35	WE10.B40.063	30.00
10	100	35	WE10.B40.100	35.00
10	160	35	WE10.B40.160	50.00
12	63	42	WE12.B40.063	30.00
12	100	42	WE12.B40.100	35.00
12	160	42	WE12.B40.160	50.00
14	63	44	WE14.B40.063	30.00
14	100	44	WE14.B40.100	35.00
14	160	44	WE14.B40.160	50.00
16	63	48	WE16.B40.063	30.00
16	100	48	WE16.B40.100	35.00
16	160	48	WE16.B40.160	50.00
18	63	50	WE18.B40.063	30.00
18	100	50	WE18.B40.100	35.00
18	160	50	WE18.B40.160	50.00
20	63	52	WE20.B40.063	30.00
20	100	52	WE20.B40.100	35.00
20	160	52	WE20.B40.160	50.00
25	63	65	WE25.B40.063	40.00
25	90	65	WE25.B40.090	40.00
25	160	65	WE25.B40.160	55.00
32	63	72	WE32.B40.063	40.00
32	100	72	WE32.B40.100	40.00
32	160	72	WE32.B40.160	60.00

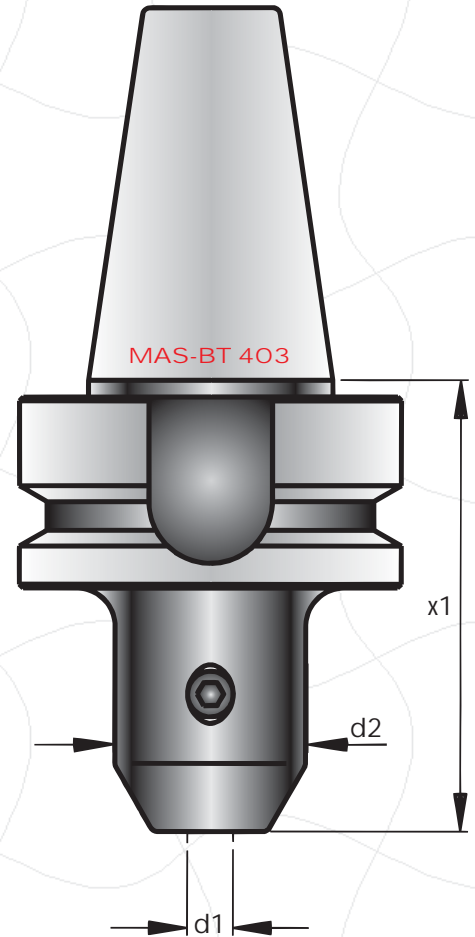

Rezervni dijelovi/Ersatzteile/Spare parts/Accessoires

Weldon	code	EUR
6	WE.06	1.00
8	WE.08	1.00
10	WE.10	1.00
12	WE.12	1.00
14	WE.14	1.00



Weldon	code	EUR
16	WE.16	2.00
18	WE.18	2.00
20	WE.20	2.00
25	WE.25	3.00
32	WE.32	3.00
40	WE.40	3.00

Zwischenhülsen für Zylinderschäfte
Adaptor sleeves for parallel shanks
Douilles intermediaires pour queues cylindriques

Isporuka : sa ugrađenim vijcima za stezanje

Lieferumfang : mit eingebauter Spannschraube

Delivery : adaptor with built in locking screw

Livraison : compris vis de serrage

MAS-BT
50

d1	x1	d2	MAS-BT 403	EUR
6	63	25	WE06.B50.063	56.00
8	63	28	WE08.B50.063	56.00
10	80	32	WE10.B50.080	56.00
12	80	42	WE12.B50.080	56.00
14	80	44	WE14.B50.080	56.00
16	80	48	WE16.B50.080	56.00
18	80	50	WE18.B50.080	56.00
20	80	52	WE20.B50.080	56.00
25	100	65	WE25.B50.100	59.00
32	105	72	WE32.B50.105	68.00
40	105	90	WE40.B50.105	79.00

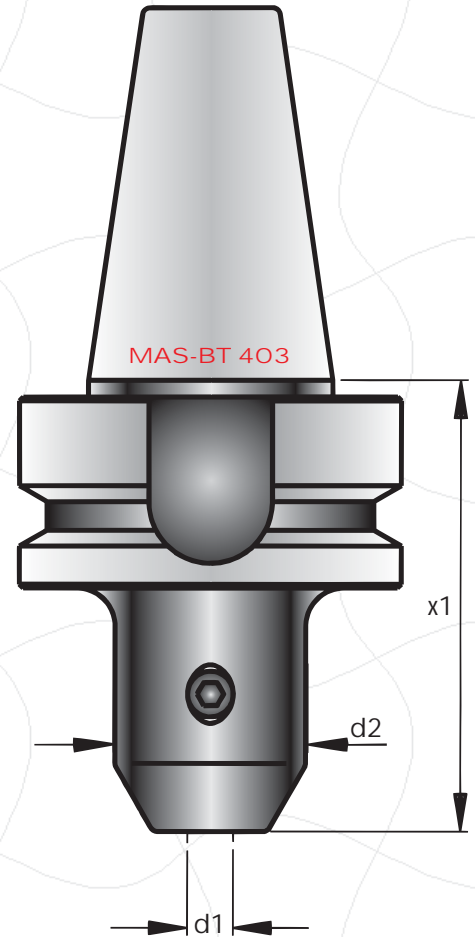

Rezervni dijelovi/Ersatzteile/Spare parts/Accessoires

Weldon	code	EUR
6	WE.06	1.00
8	WE.08	1.00
10	WE.10	1.00
12	WE.12	1.00
14	WE.14	1.00



Weldon	code	EUR
16	WE.16	2.00
18	WE.18	2.00
20	WE.20	2.00
25	WE.25	3.00
32	WE.32	3.00
40	WE.40	3.00

Spannzangenfutter 8° für Spannzangen DIN6499

Collet chucks 8° for collets DIN6499

Mandrins porte-pinces 8° pour pinces de serrage DIN6499

Isporuka : sa ugrađenom maticom za stezanje i vijkom za uzdu no podešavanje

Lieferumfang : mit Spannmutter und Verstellerschraube

Delivery : with clamping nut and adjusting screw

Livraison : Ecrous de serrage et vis de réglage

MAS-BT
40

TIP	Prihvat mm Spannbereich mm Clamping range mm Capacité de serrage mm	x1	d1	MAS-BT 403	EUR
ER16	0.5-10	63	28	ER16.B40.063	40.00
ER16	0.5-10	100	28	ER16.B40.100	50.00
ER16	0.5-10	160	28	ER16.B40.160	75.00
ER25	1-16	60	42	ER25.B40.060	40.00
ER25	1-16	100	42	ER25.B40.100	50.00
ER25	1-16	160	42	ER25.B40.160	75.00
ER32	2-20	70	50	ER32.B40.070	42.00
ER32	2-20	100	50	ER32.B40.100	52.00
ER32	2-20	160	50	ER32.B40.160	80.00
ER40	3-26	80	63	ER40.B40.080	45.00
ER40	3-26	160	63	ER40.B40.160	82.00

MAS-BT
50

TIP	Prihvat mm Spannbereich mm Clamping range mm Capacité de serrage mm	x1	d1	MAS-BT 403	EUR
ER16	0.5-10	100	28	ER16.B50.100	75.00
ER32	2-20	70	50	ER32.B50.070	75.00
ER40	3-26	80	63	ER40.B50.080	75.00

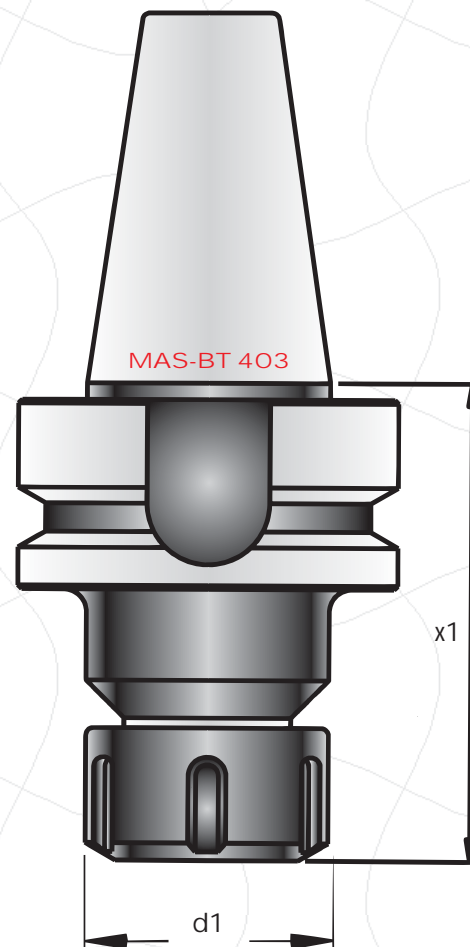

Elastiène èahure ER : vidi stranu 6.03-6.04

Spannzangen ER : siehe Seite 6.03.-6.04

Collets ER : see page 6.03 - 6.04

Pinces de serrage ER : Voir page 6.03 -.6.04

Rezervni dijelovi/Ersatzteile/Spare parts/Accessoires



ER	code	EUR
16	D6499.ER16	12.00
25	D6499.ER25	14.00
32	D6499.ER32	14.00
40	D6499.ER40	16.00

ER	code	EUR
16	KLJ.ER16	10.00
25	KLJ.ER25	12.00
32	KLJ.ER32	14.00
40	KLJ.ER40	16.00

ER	code	EUR
16	VP.ER16	2.00
25	VP.ER25	3.00
32	VP.ER32	3.00
40	VP.ER40	3.00

Spannzangenfutter 1:10 für Spannzangen DIN6388

Collet chucks 1:10 for collets DIN6388

Mandrins porte-pinces 1:10 pour pinces de serrage DIN6388

Isporuka : sa ugrađenom maticom za stezanje i vijkom za uzdu no podešavanje

Lieferumfang : mit Spannmutter und Verstellerschraube

Delivery : with clamping nut and adjusting screw

Livraison : Ecrous de serrage et vis de réglage

**MAS-BT
40**

Prihvat mm Spannbereich mm Clamping range mm Capacite de serrage mm	x1	d1	MAS-BT 403	EUR
1.5-16	70	43	SP16.B40.070	51.00
2-25	70	60	SP25.B40.070	55.00
4-32	90	72	SP32.B40.090	58.00

**MAS-BT
50**

Prihvat mm Spannbereich mm Clamping range mm Capacite de serrage mm	x1	d1	MAS-BT 403	EUR
1.5-16	70	43	SP16.B50.070	72.00
2-25	70	60	SP25.B50.070	73.00
4-32	90	72	SP32.B50.090	78.00

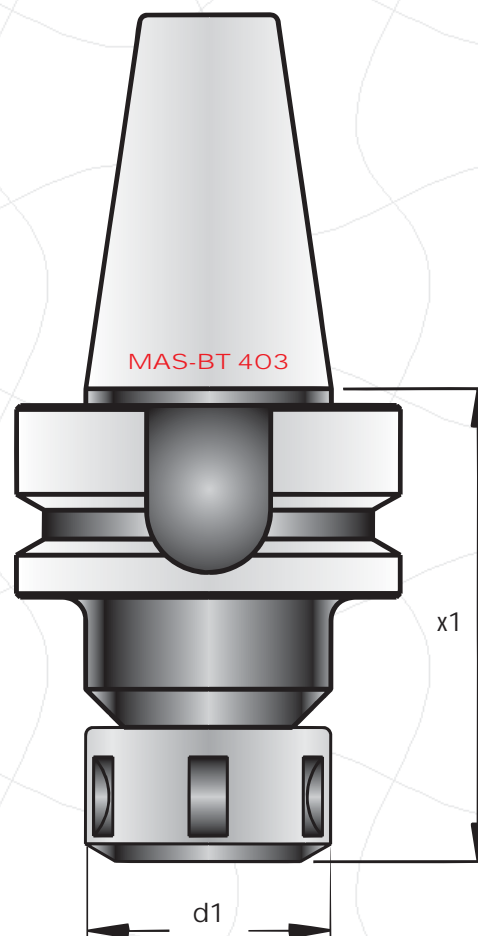

Elastiène èahure DIN6388 : vidi stranu 6.05-6.06

Spannzangen DIN6388 : siehe Seite 6.05-6.06

Collets DIN6388 : see page 6.05-6.06

Pincés de serrage DIN6388 : Voir page 6.05-6.06

Rezervni dijelovi/Ersatzteile/Spare parts/Accessoires



Prihvat mm Spannbereich mm Clamping range mm Capacite de serrage mm	code	EUR
1.5-16	D6388.116	22.00
2-25	D6388.225	24.00
4-32	D6388.320	29.00

Prihvat mm Spannbereich mm Clamping range mm Capacite de serrage mm	code	EUR
1.5-16	KLJ.SP116	7.00
2-25	KLJ.SP225	9.00
4-32	KLJ.SP432	9.00

Prihvat mm Spannbereich mm Clamping range mm Capacite de serrage mm	code	EUR
1.5-16	VP.116	3.00
2-25	VP.225	3.00
4-32	VP.432	3.00

Zwischenhülsen für Morsekegelschäfte mit Austreibblappen DIN228 B
Adaptor sleeves for Morse taper shanks
Douilles intermediaires pour outils a cone Morse

MAS-BT
40

MK	x1	d1	MAS-BT 403	EUR
1	50	25	MK1B.B40.050	30.00
2	50	32	MK2B.B40.050	30.00
3	70	40	MK3B.B40.070	30.00
4	95	48	MK4B.B40.095	35.00

MAS-BT
50

MK	x1	d1	MAS-BT 403	EUR
1	45	25	MK1B.B50.045	50.00
2	60	32	MK2B.B40.060	50.00
3	65	40	MK3B.B40.065	50.00
4	95	48	MK4B.B40.095	53.00
5	100	63	MK5B.B50.100	55.00

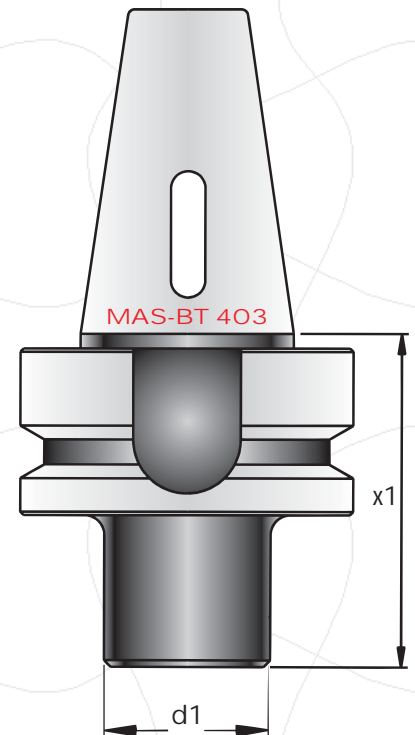

Zwischenhülsen für Morsekegelschäfte mit Anzugsgewinde DIN228 A
Adaptor sleeves for Morse taper shanks and drawing thread
Douilles intermediaires pour outils a cone Morse a trou filete

Isporuka : sa ugrađenim imbus vijkom za stezanje

Lieferumfang : mit eingebauter Innensechskantschraube

Delivery : with built-in draw screw

Livraison : avec vis de incorporee

MAS-BT
40

MK	x1	d1	MAS-BT 403	EUR
1	50	25	MK1A.B40.050	50.00
2	50	32	MK2A.B40.050	50.00
3	70	40	MK3A.B40.070	50.00
4	95	48	MK4A.B40.095	55.00

MAS-BT
50

MK	x1	d1	MAS-BT 403	EUR
1	45	25	MK1A.B50.045	85.00
2	60	32	MK2A.B50.060	85.00
3	65	40	MK3A.B50.065	85.00
4	70	48	MK4A.B50.070	90.00

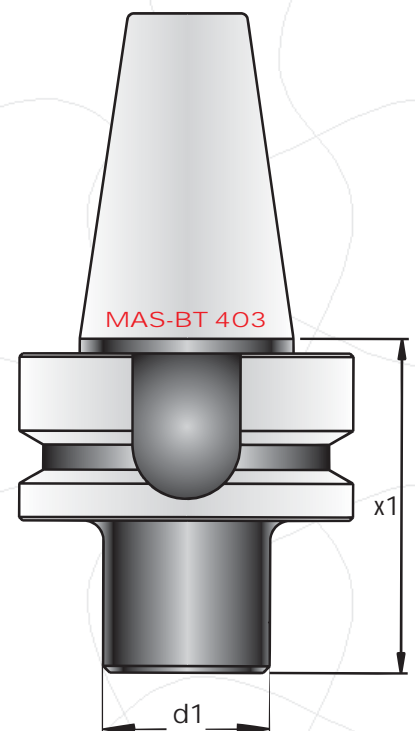

Kombi-Aufsteckfräserdorne mit Längs- oder Quernut DIN6358
Combi shell mill holders for cutters with longitudinal or transverse drive
Mandrins porte-fraises pour fraises a entrainement par clavette ou tenon

Isporučka : sa ugrađenim klinom, povlačenim prstenom te križnim vijkom

Lieferumfang : mit Paßfeder, Mitnehmerring und Fräseranzugschraube

Delivery : with driving key, driving ring and cross screw

Livraison : avec entrainement par tenons ou clavette et vis serrage

MAS-BT
40

d1	x1	x2	d2	l2	MAS-BT 403	EUR
16	55	45	32	27	KD16.B40.055	40.00
22	55	43	40	31	KD22.B40.055	40.00
27	55	43	48	33	KD27.B40.055	40.00
32	60	46	58	38	KD32.B40.060	45.00
40	60	46	70	41	KD40.B40.060	50.00

MAS-BT
50

d1	x1	x2	d2	l2	MAS-BT 403	EUR
16	70	45	32	27	KD16.B50.070	58.00
22	70	43	40	31	KD22.B50.070	58.00
27	70	43	48	33	KD27.B50.070	60.00
32	70	46	58	38	KD32.B50.070	62.00
40	70	46	70	41	KD40.B50.070	67.00

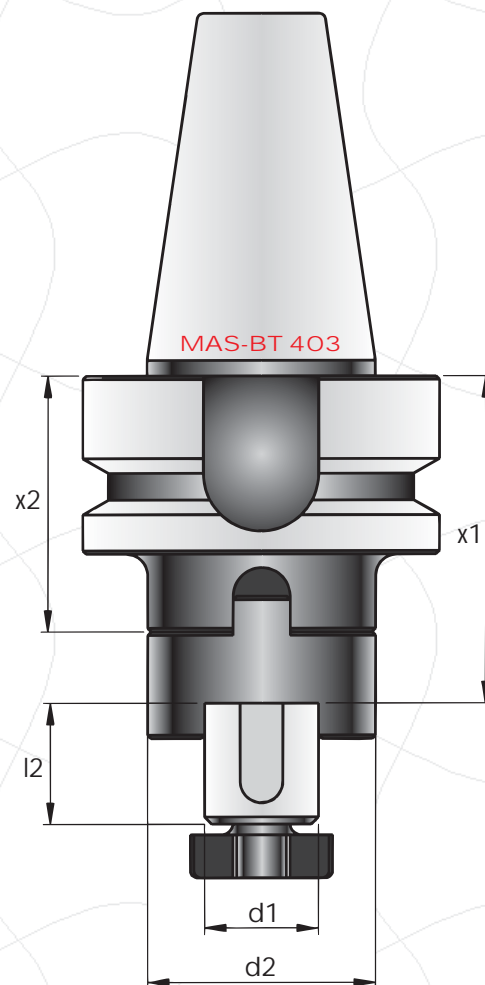

Rezervni dijelovi/Ersatzteile/Spare parts/Accessoires

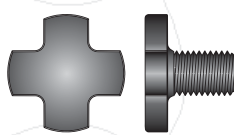

d1	code	EUR
16	D6366.16	7.00
22	D6366.22	8.00
27	D6366.27	9.00
32	D6366.32	12.00
40	D6366.40	16.00

d1	M	code	EUR
16	M08	D6367.M08	2.00
22	M10	D6367.M10	3.00
27	M12	D6367.M12	4.00
32	M16	D6367.M16	6.00
40	M20	D6367.M20	8.00

d1	code	EUR
16	UP.04420	1.00
22	UP.06622	1.00
27	UP.07725	1.00
32	UP.08730	2.00
40	UP10832	3.00

Aufsteckfräserdorne mit Quernut DIN6357
Shell mill holders for cutters with driving slot
Mandrins porte-fraises pour porte-fraises a lames amovibles

Isporuka : sa ugrađenim klinovima i kri nim vijkom

Lieferumfang : mit eingebauten Mitnehmersteine und Fräseranzugschraube

Delivery : with driving keys and cross screw

Livraison : avec entrainement par tenons et vis serrage

MAS-BT
40

d1	x1	l1	d2	MAS-BT 403	EUR
22	35	19	50	AD22.B40.035	40.00
27	35	21	50	AD27.B40.035	40.00
32	50	24	78	AD32.B40.050	42.00
40	50	27	89	AD40.B40.050	49.00

MAS-BT
50

d1	x1	l1	d2	MAS-BT 403	EUR
22	55	19	50	AD22.B50.055	70.00
27	55	21	50	AD27.B50.055	70.00
32	55	24	78	AD32.B50.055	72.00
40	55	27	89	AD40.B50.055	85.00

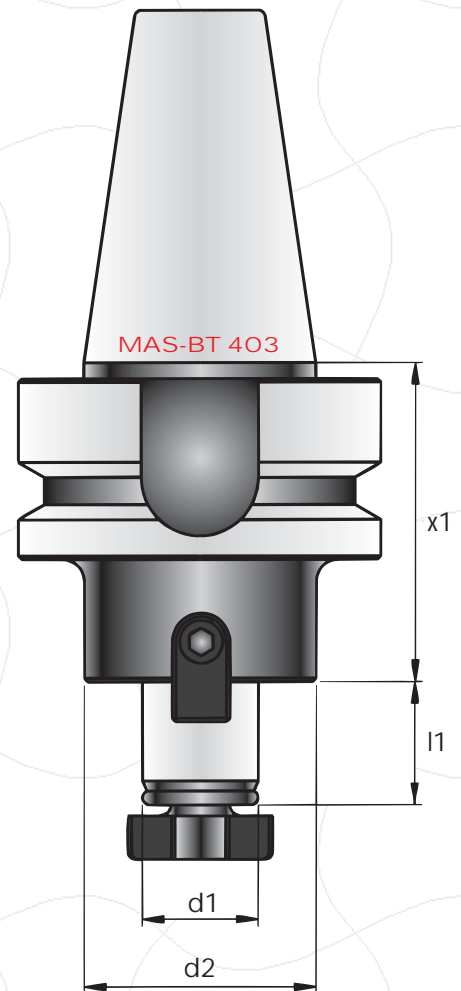

Rezervni dijelovi/Ersatzteile/Spare parts/Accessoires

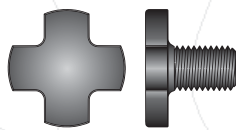

d1	M	code	EUR
16	M08	D6367.M08	2.00
22	M10	D6367.M10	3.00
27	M12	D6367.M12	4.00
32	M16	D6367.M16	6.00
40	M20	D6367.M20	8.00
50	M24	D6367.M24	12.00



d1	code	EUR
16	PK.16	5.00
22	PK.22	6.00
27	PK.27	7.00
32	PK.32	8.00
40	PK.40	9.00
50	PK.50	10.00

Schrumpffutter zum spannen HM und HSS Zylinderschäften

Shrink chucks for clamping HM and HSS cylindrical shanks

Les Mandrins de frettage pour le serrage carbure et HSS queues cylindriques

Od d1 = 3 do d1 = 5, bez vijka za podešavanje dužine

Von d1 = 3 bis d1 = 5, ohne Stellschraube

From d1 = 3 till d1 = 5, without adjusting screw

De d1 = 3 au d1 = 5, sans vis de fixation

MAS-BT
50 G2.5-15.000

d1	x1	x2	d2	d3	MAS-BT 403 AD+B	EUR
6	90	36	21	27	SF06.B55.090	170.00
6	130	36	21	27	SF06.B55.130	190.00
6	160	36	21	27	SF06.B55.160	220.00
6	200	36	21	27	SF06.B55.200	250.00
8	90	36	21	27	SF08.B55.090	170.00
8	130	36	21	27	SF08.B55.130	190.00
8	160	36	21	27	SF08.B55.160	220.00
8	200	36	21	27	SF08.B55.200	250.00
10	90	42	24	32	SF10.B55.090	170.00
10	130	42	24	32	SF10.B55.130	190.00
10	160	42	24	32	SF10.B55.160	220.00
10	200	42	24	32	SF10.B55.200	250.00
12	90	47	24	32	SF12.B55.090	170.00
12	130	47	24	32	SF12.B55.130	190.00
12	160	47	24	32	SF12.B55.160	220.00
12	200	47	24	32	SF12.B55.200	250.00
14	90	47	27	34	SF14.B55.090	170.00
14	130	47	27	34	SF14.B55.130	190.00
14	160	47	27	34	SF14.B55.160	220.00
14	200	47	27	34	SF14.B55.200	250.00
16	90	50	27	34	SF16.B55.090	170.00
16	130	50	27	34	SF16.B55.130	190.00
16	160	50	27	34	SF16.B55.160	220.00
16	200	50	27	34	SF16.B55.200	250.00
18	90	50	33	42	SF18.B55.090	170.00
18	130	50	33	42	SF18.B55.130	190.00
18	160	50	33	42	SF18.B55.160	220.00
18	200	50	33	42	SF18.B55.200	250.00
20	90	52	33	42	SF20.B55.090	170.00
20	130	52	33	42	SF20.B55.130	190.00
20	160	52	33	42	SF20.B55.160	220.00
20	200	52	33	42	SF20.B55.200	250.00
25	100	58	44	53	SF25.B55.100	180.00
25	130	58	44	53	SF25.B55.130	190.00
25	160	58	44	53	SF25.B55.160	220.00
25	200	58	44	53	SF25.B55.200	250.00
32	100	58	44	53	SF32.B55.100	180.00
32	160	58	44	53	SF32.B55.160	220.00
32	200	58	44	53	SF32.B55.200	250.00

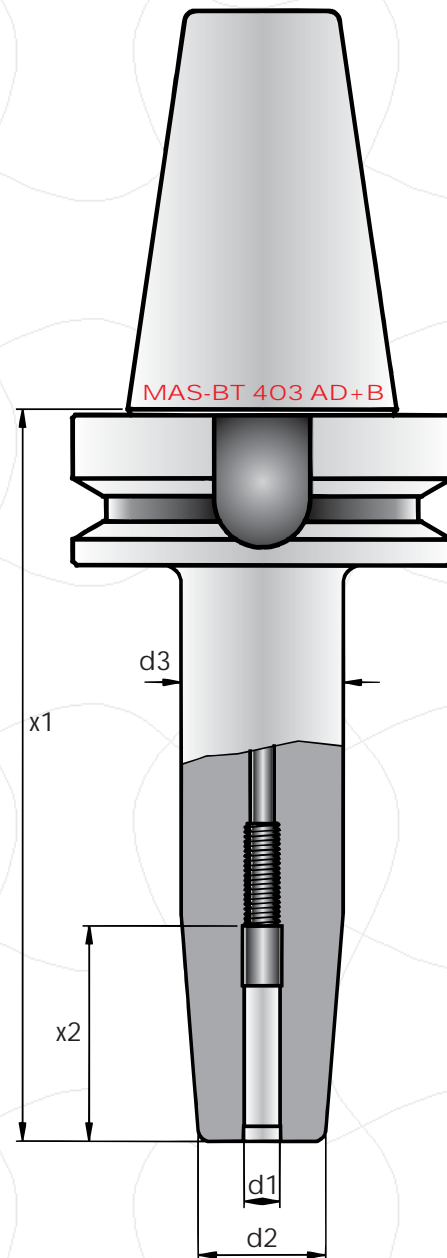

Cilindrièni produci "SCHRUMPFUTTER"

Verlängerungen für Schrumpffutter

Extensions for shrink chucks

Prolongations pour les Mandrins de frettage

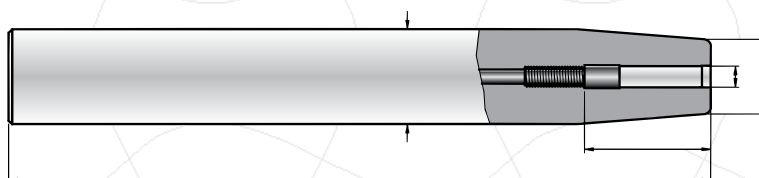

Vidi stranu 6.9

Siehe Seite 6.9

See page 6.9

Voir page 6.9

NC Kurzbohrfutter für Rechtslauf
NC drill chucks for RH drilling
Mandrins de perçage NC pour marche à droite

MAS-BT
40

Prihvata od-do Spannweite mm Holding capacity Capacité de serrage	x1	d1	MAS-BT 403	EUR
0-8	78	38	NC08.B40.078	150.00
1-13	86	48	NC13.B40.086	140.00
3-16	105	55	NC16.B40.105	150.00

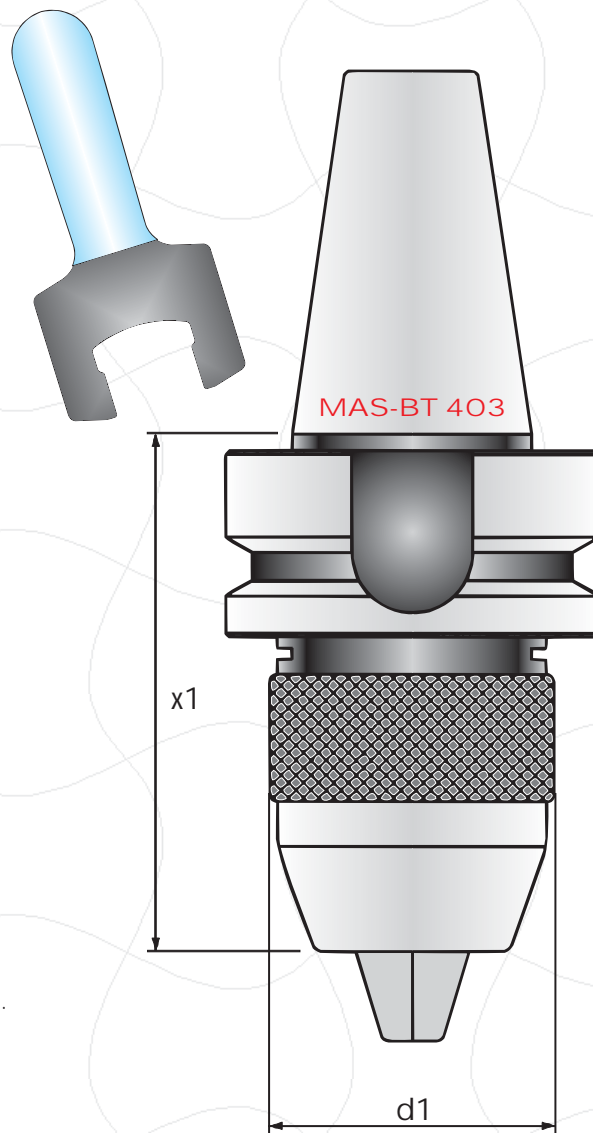

OPIS :

NC stezne glave sa velikim momentom stezanja.
Stežanje pomoću specijalnog ključa.
Dvostruki moment u odnosu na ručno stežanje.
Proklizavanje svrdla gotovo nemoguće.
Proklizavanje same stezne glave nije moguće, jer je stegnuta za nosač pomoću vijka.
Kratka izvedba
Vanjsko hlađenje
Isporuka sa specijalnim ključem

BEMERKUNGEN :

NC Kurzbohrfutter mit hoher Spannkraft durch Schlüssel-Spannung.
Doppelt gegenüber Handanzug
Unbeabsichtigtes Ablösen des Bohrers nahezu unmöglich.
Dadurch, dass das Bohrfutter fest mit dem Schaft verschraubt ist, kann sich auch dieses nicht lösen.
Kurze Bauform
Externe Kühlmittelzufuhr
Spannbereich bis 13 und 16 mm
mit Spezialschlüssel.

DESCRIPTION :

Integral drill chucks with high clamping force,
through special wrench.
2 times chucking torque against hand tightening.
Slipping-off of the drill nearly impossible.
Slipping-off of the drill chuck impossible,
as the chuck is screwed with the body.
Short design.
External coolant supply.
Range up to 13 and 16 mm
Special wrench included.

Stežna glava, sistem :
Kopfsystem :
Head system :
Système de tête :

LLAMBRICH

REMARQUES :

Mandrin de perçage court avec effort de tension haut par tension
avec clef spéciale .
Double vis-à-vis tension à la main
Se détacher du foret sans intention presque impossible
Puisque le mandrin de perçage est solidement vissé avec la queue,
il ne peut pas se détacher non plus .
Construction courte
Liquide de refroidissement extérieur
Capacité de serrage à 13 mm et à 16 mm
Avec clef spéciale.

NC Kurzbohrfutter für Links- und Rechtslauf
NC drill chucks for CW and CCW rotation
Mandrins de perçage NC pour marche a droite et a gauche

MAS-BT
40

Prihvati od-do

Spannweite mm Holding capacity Capacité de serrage	x1	d1	MAS-BT 403	EUR
1,0-13	96	54	HX13.B40.096	200.00
3,0-16	99	57	HX16.B40.099	235.00
1,0-13**	96	54	HX13.B40.096.IK	215.00
3,0-16**	99	57	HX16.B40.099.IK	250.00

MAS-BT
50

Prihvati od-do

Spannweite mm Holding capacity Capacité de serrage	x1	d1	MAS-BT 403	EUR
1,0-13	107	54	HX13.B50.107	250.00
3,0-16	110	57	HX16.B50.110	270.00
1,0-13**	107	54	HK13.B50.107.IK	265.00
3,0-16**	110	57	HX13.B50.110.IK	285.00

** unutarne hlađenje/ IKZ/ internal coolant/ arrosage central

Precizna stezna glava sa integriranom drškom.

Stežanje imbus ključem.
Za upotrebu na CNC strojevima sa visokim brojem okretaja.
Bušenje, glodanje, razvrtavanje, urezivanje navoja.
Rad u lijevo i u desno (za strojeve s košenjem motora).
Veliki moment stezanja >100Nm.
Maksimalan pritisak tekućine za hlađenje : 50 bara
Visoka točnost radijalnog udara <0.03 mm
Maksimalni broj okretaja, bez balansiranja = 8.000
Fino balansiranje G6.3-25.000 o/min, na upit

Präzision-Kurzbohrfutter

Anwendung in Hochgeschwindigkeits-CNC-Maschinen
Bohr-, Fräs-, Reib-, Gewindeschneidaufgaben
Spannen mit Sechskantschlüssel
Für Rechts- und Linkslauf
Anzugsmoment über 100 Nm
Maximale Rundlaufabweichung 0,03 mm
Maximaler Kühlmitteldruck: 50 bar
Maximale Drehzahl ungewuchtet 8000 U/min
Wuchtgute wahlweise bis 25.000 U/min G6.3

Precision drill chuck with integrated shank and hexagonal key lock

For use on high-speed CNC machines
Drilling, milling, reaming, tapping
Permits CW and CCW turning
High gripping torque, exceeding 100 Nm
Maximum total integrated run-out of 0.03 mm.
Maximum coolant pressure 50 bar
Maximum rpm without balancing 8000 rpm
Optional balancing service up to G6.3-25.000 rpm

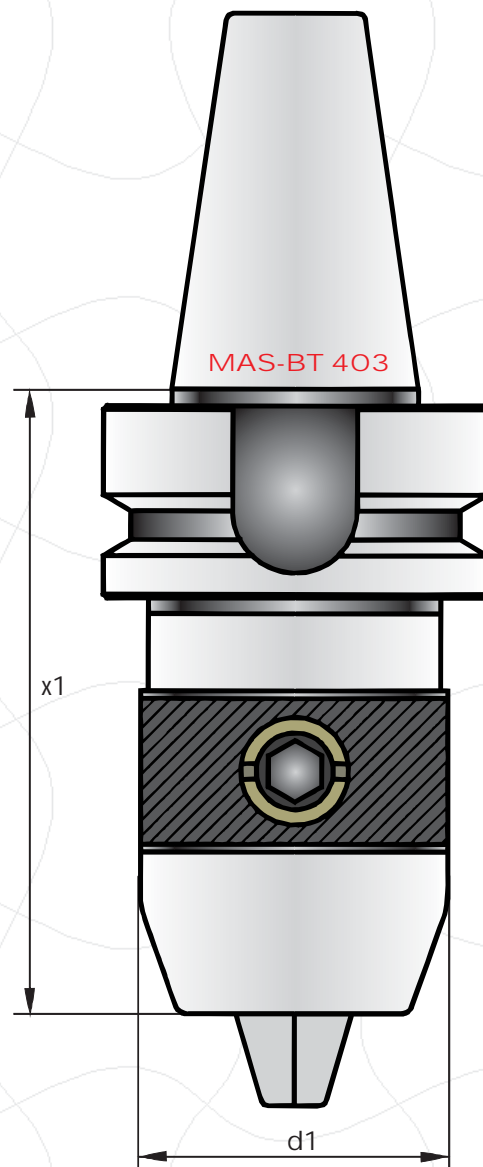

Stezna glava, sistem :
Kopfsystem :
Head system :
Systeme de tete :

LLAMBRICH

Mandrin de perçage de précision, monobloc

Pour les machinec CNC a grande vitesse
Perçage, fraisage, alésage et filetage
Serrage avec Cle Six Pans
Permet la rotation a droite ou a gauche
Couple de serrage superieur a 100 Nm
Pression maxi pour liquide de refroidissement 50 bars
Excentricite maximum de 0.003
Vitesse maximale sans equilibrage 8.000 rpm
Service optionell d' equilibrage jusqu' au 25.000 rpm

Gewindeschneid-Schnellwechselfutter mit elastischem Längenausgleich
auf Druck und Zug

Tapping head quick-change with length compensation in
compression and tension

Mandrins de taraudage a changement rapide pour la taille des filets avec compensation
longitudinale de la pression et de la traction

MAS-BT 40

Ureznik od-do für Gewindebohrer for tapping drill pour tarauds	Kompenzacija Längenausgleich Compensation Compensation	dr aèi ureznika Schnellwechsel Einsätze Fastchangeable inserts Meches a serrage rapide	x1	d1	MAS-BT 403	EUR
M3-M12	9 mm	Vel.1	66,5	36	GN12.B40.066	195.00
M8-M20	15 mm	Vel.2	93,5	53	GN20.B40.093	210.00
M14-M33	24 mm	Vel.3	162,5	78	GN33.B40.162	410.00
M22-M48	26 mm	Vel.4	182,0	96	GN48.B40.182	630.00

MAS-BT 50

Ureznik od-do für Gewindebohrer for tapping drill pour tarauds	Kompenzacija Längenausgleich Compensation Compensation	dr aèi ureznika Schnellwechsel Einsätze Fastchangeable inserts Meches a serrage rapide	x1	d1	MAS-BT 403	EUR
M3-M12	9 mm	Vel.1	81,0	36	GN12.B50.081	265.00
M8-M20	15 mm	Vel.2	101,5	53	GN20.B50.101	290.00
M14-M33	24 mm	Vel.3	141,0	78	GN33.B50.141	430.00
M22-M48	26 mm	Vel.4	164,5	96	GN48.B50.164	690.00

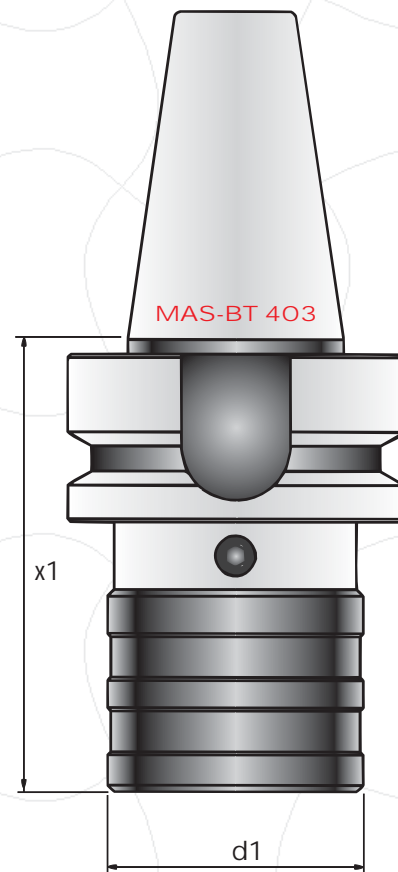

Dr aèi ureznika

Schnellwechsel - Einsätze
Quick change tapping inserts
Meches a serrage rapide

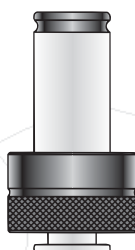

Vidi strane 6.7-6.8

Siehe Seiten 6.7 - 6.8

See pages 6.7 - 6.8

Voir page 6.7 - 6.8

